

DIAPHRAGM TYPE HOMOGENIZER PRESSURE GAUGE

Special Features:

- Suitable To Use in Dairy Homogenizer Machines
- Fillable Version Facilitate Usage in Vibration Zones To Avoid Damages To Its Mechanism.



Applications:

These gauges are being used in applications where hygiene is of Prime importance like dairy, food, beverages & pharmaceutical Industries.

Specifications:

Standard Version: : 100mm, 150mm

Accuracy	:	±1.6% of F.S.
Ambient temperature	:	- 25°C to + 65°C
Process temperature	:	Max. 120°C
Operating pressure	:	75% of the Scale Value



Case	:	AISI 304 SS
Ring	:	AISI 304 SS, Bayonet Type
Bourdon	:	AISI 316 SS
Socket	:	AISI 316 SS
Movement	:	AISI 304 SS
Diaphragm	:	AISI 316L SS
Body	:	AISI 316 SS
Joints	:	Tig Argon Arc Welding



Protection	:	IP 65
Dial	:	Aluminium, White with Black Marking & Anti parallax Mirror Band
Pointer	:	Aluminium, black coloured micrometer zero adjustable
Window	:	Plexi Glass
Blow off Disc	:	Neoprene
Gasket	:	Neoprene
Sealing liquid	:	Food grade oil
Dampening Liquid	:	Glycerine 98%



DIAPHRAGM TYPE HOMOGENIZER PRESSURE GAUGE

DIMENSIONS - STANDARD VERSION

TYPE H02

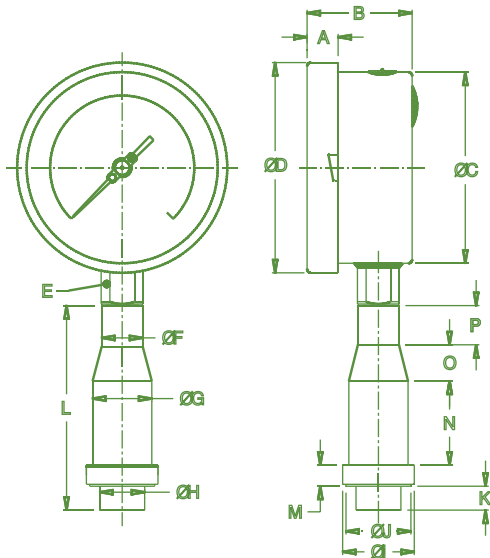

WITHOUT FLANGE CONNECTION

NS	A	B	ØC	ØD	E	ØF	ØG	ØH	ØI	Øj	K	L	M	N	O	P
150	12.5	48	100	110	22	21.5	23.5	15	37.5	34	12	106.5	11	44.5	19	20
150	15	49	149	161	22	21.5	23.5	15	37.5	34	12	106.5	11	44.5	19	20

TYPE H01

FLANGE CONNECTION

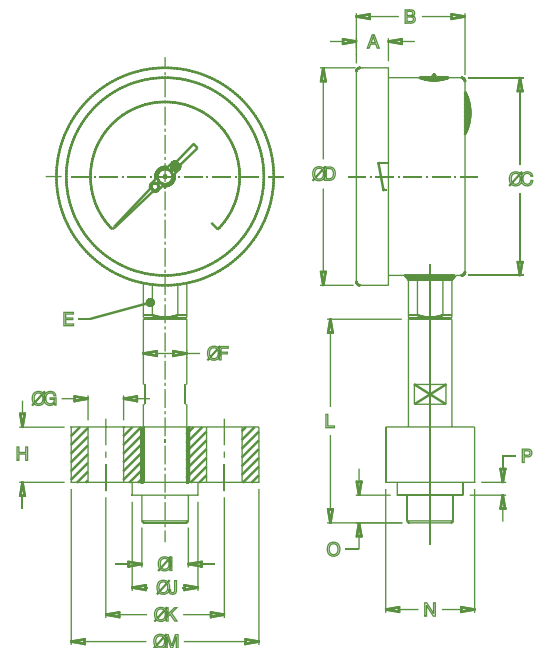

NS	A	B	ØC	ØD	E	ØF	ØG	H	ØI	ØJ	ØK	L	ØM	N	O	P
150	12.5	48	100	110	22	22	18	28	23.5	33.3	60	102	95	45	13	6.5
150	15	49	149	161	22	22	18	28	23.5	33.3	60	102	95	45	13	6.5

DIAPHRAGM TYPE HOMOGENIZER PRESSURE GAUGE

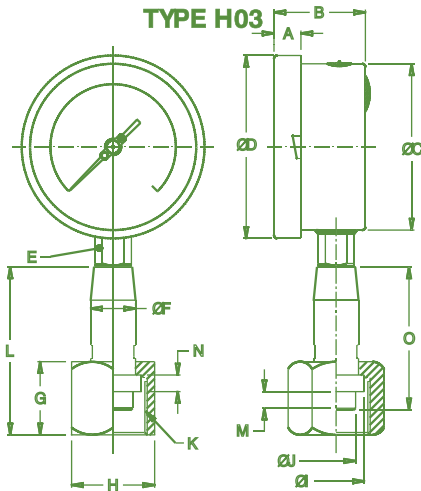

WITHOUT FLANGE CONNECTION

NS	A	B	ØC	ØD	E	ØF	ØG	ØH	Øi	Øj	K	L	M	N	O	P
150	12.5	48	100	110	22	21.5	23.5	15	37.5	34	12	106.5	11	44.5	19	20
150	15	49	149	161	22	21.5	23.5	15	37.5	34	12	106.5	11	44.5	19	20

HOW TO ORDER

Basic Model:

PGH

CODE

C

D

C

Nominal Size(mm)

100 mm

150 mm

Type Of Mounting:

1. Direct Bottom Entry

Gauge Connection:

H01

H01 Flange

H02 With Out Flange

H03 1 1/4" BSP (F)

RANGE (in kg/cm² or bar)

0-250

0/160

0/250

0/400

0/600

0/1000

Options:

RH

PW Five Point Calibration Certificate

FG Oxygen Service

SX SS Tag Plate

TB Helium Leak Test

RH Custom Designed Dial

Ordering Example : PGH - C - H01 - 0-250 - RH

Note : Due to continuous improvement, the specification may vary from time to time.