

## SOLID FRONT TEST GAUGE

### Special Features:

- Stainless Steel Case & High Precision Measuring System
- Anti Parallax Mirror
- Solid Front Design Features Baffle Wall Interposed Between The Sensing System & The Window, And A Pressure Relieving Back For Increased Safety.
- Eye Friendly Green Dial
- Standard Followed In General EN 837-1



### Applications:

CALIBRATION LABORATORY & PRECISION READING

### Specifications:

Standard Version: 150mm

Accuracy	: ±0.25% of F.S.
Ambient temperature	: Upto 65°C
Process temperature	: Max 65°C
Calibration temperature	: +22°C
Operating pressure	: 75% of the Scale value
Over pressure limit	: Referred to full Scale Value



Case	: AISI 304 Solid front case
Ring	: AISI 304 SS (Bayonet Type)
Bourdon	: Beryllium Copper
Socket	: AISI 316L SS
Blow off Disc	: AISI 304 SS
Movement	: Brass High Precision Jewel Bearing Type
Welding	: Alloy Brazing



Protection	: IP 55
Dial	: Aluminium, White with Black Marking & Anti parallax Mirror Band
Pointer	: Balanced, Knife - Edge Micrometer Adjustable
Pointer Stopper	: Spring Type
Window	: Shatterproof/Safety Glass
Gasket	: Neoprene
Carrying Case	: Wooden carrying case
Calibration certificate	: 5 Point traceable calibration certificate



## SOLID FRONT TEST GAUGE

### DIMENSIONS - STANDARD VERSION

#### ⚙️ Type 1

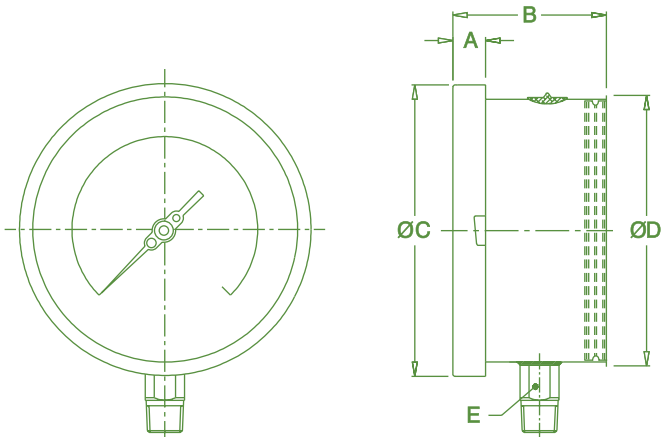

NS	A	B	ØC	ØD	E	F
100	12.5	48	100	110	22	43.5
150	15	49	149	161	22	43.5

#### ⚙️ Type 2

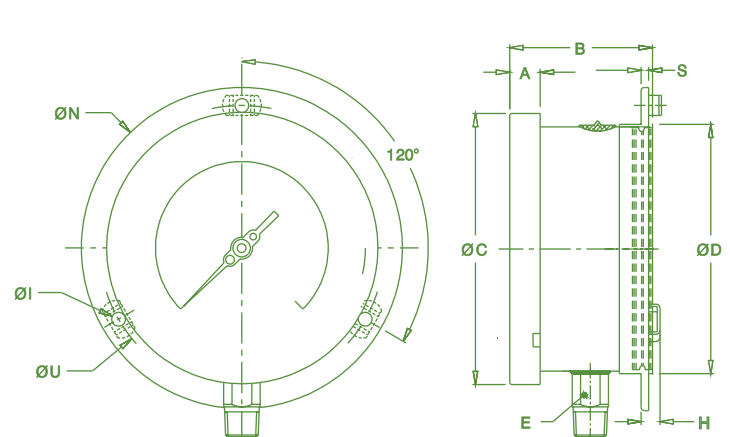

NS	A	B	ØC	ØD	E	ØN	ØU	H	ØI	S
150	15	66	161	149	22	196	178	15	6	5

Notes : • Drawings are not to scale. • All Dimensions are in mm. • NS = Nominal Size

## RANGE TABLE

Note : Single scale available in kg/cm , psi, bar, kPa, MPa, mmHg etc.  
Following are the example tables for kg/cm scales

#### ⚙️ Pressure:

##### SINGLE SCALE

RANGE (kg/cm <sup>2</sup> )	RANGE (kg/cm <sup>2</sup> )	RANGE (kg/cm <sup>2</sup> )	RANGE (kg/cm <sup>2</sup> )	RANGE (kg/cm <sup>2</sup> )
-1/0	0/4	0/25	0/160	
0/0.6	0/6	0/40	0/250	0/1000
0/1	0/10	0/60	0/400	
0/1.6	0/16	0/100	0/600	
0/2.5				

## SOLID FRONT TEST GAUGE

### HOW TO ORDER

#### Basic Model:

PGMG

CODE	D
Nominal Size(mm)	150

D

#### Type Of Mounting:

2

1. Direct Bottom Entry
2. Wall/ Surface/ Projection With Bottom Entry

#### Gauge Connection:

06N

10B	3/8" BSP (M)	06B	1/4" BSP (M)
15B	1/2" BSP (M) (STANDARD)	06N	1/4" NPT (M)
15N	1/2" NPT (M) (STANDARD)		

#### Range:

0-10  
kg/cm<sup>2</sup>

Refer tables

#### Options:

SG

RH	CUSTOM DESIGNED DIAL
SG	OXYGEN SERVICE
SW	DIAL TAG MARKING
SX	SS TAG PLATE

FOR NON STANDARD PRODUCTS/OPTIONAL ITEMS, PLEASE CONTACT FACTORY FOR DELIVERY AND MINIMUM QUANTITY OF ORDER

Ordering Example : PGMG - D - 2 - 06N - 0/10kg/cm<sup>2</sup> - SG

Note : Due to continuous improvement, the specification may vary from time to time.